

ATLANTIS® 40



Atex   II 2 GD³

* on request * NA VYŽADÁNÍ

art. B302 from DN 40 to DN 200 - GGG40 / 304 / NBR // od DN 40 do DN 200 - GGG40 / 304 / NBR



art. B302	od DN 40 do DN 200 GGG40 / 304 / NBR
art. B307	od DN 40 do DN 200 GGG40 / 316 / NBR



art. B322	od DN 250 do DN 600 GGG40 / 304 / NBR
art. B327	od DN 250 do DN 300 GGG40 / 316 / NBR



art. B306	od DN 40 do DN 200 GGG40 / 316 / EPDM
art. B30A	od DN 40 do DN 200 GGG40 / GGG40 NICK / EPDM
art. B308	od DN 40 do DN 200 GGG40 / 316 / VITON



art. B326	od DN 250 do DN 600 GGG40 / 316 / EPDM
art. B32A	od DN 250 do DN 600 GGG40 / GGG40 NICK / EPDM
art. B328	od DN 250 do DN 300 GGG40 / 316 / VITON

MAIN STANDARD FEATURES:

CONSTRUCTION:

- **GENERAL SPECIFICATIONS:** BS EN 593 - (BS 5155) - MSS SP67 - API 609.
 - **DIAMETERS:** DN40 - DN600.
 - **CONNECTION WITH FLANGES UNI EN 1092:**
PN6 - PN10 - PN16 DN40 - DN300
PN10 DN350 - DN600.
 - **CONNECTION WITH FLANGES ANSI 150:**
DN40 - DN300.
 - **MAXIMUM WORKING PRESSURE:**
PN16 DN40 - DN300 (for fluids)
PN16 DN40 - DN200 (for gas)
PN10 DN350 - DN600 (for fluids)
PN10 DN250 - DN600 (for gas).
 - **TEMPERATURE LIMITS WITH SEALING SEATS IN:**
EPDM -20°C / +110°C for fluids
NBR -20°C / +90°C for fluids
NBR -20°C / +60°C for gas
VITON -10°C / +150°C for fluids
VITON -10°C / +60°C for gas.
 - **FACE TO FACE DIMENSIONS IN CONFORMITY WITH:**
UNI EN 558 - ISO5752 - MSS SP67 - API609 - DIN3202/3-K1.
 - **TOP FLANGE:** drilling ISO5211.
 - **OPERATION DEVICE:** lever DN40 - DN200,
gear DN250 - DN600.
 - **LOCKING DEVICE:** DN40 - DN200.
 - Tested for vacuum at 900mbar.
 - Polyurethane coating.
- **NB:** for material compatibility please check the table with corrosion resistance at the end of the catalogue.

SPECIAL OPTIONS:

- Reduction gear with manual operation also for small DN.
- VITON seals.

ON REQUEST:

- Kit to convert from a manual valve to an actuated valve.
- For further special requests please consult our technical/commercial service.

HLAVNÍ STANDARDNÍ CHARAKTERISTIKY:

KONSTRUKCE:

- **OBECNÁ SPECIFIKACE** BS EN 593 - (BS 5155) - MSS SP67 - API 609.
 - **ROZMĚRY:** DN40 - DN600.
 - **PŘIPOJENÍ NA PŘÍRUBY DLE UNI EN 1092:**
PN6 - PN10 - PN16 DN40 - DN300
PN10 DN350 - DN600.
 - **PŘIPOJENÍ NA PŘÍRUBY DLE ANSI 150:**
DN40 - DN300.
 - **MAXIMÁLNÍ PRACOVNÍ TLAK:**
PN16 DN40 - DN300 (pro kapaliny)
PN16 DN40 - DN200 (pro plyn)
PN10 DN350 - DN600 (pro kapaliny)
PN10 DN250 - DN600 (pro plyn).
 - **TEPLOTNÍ LIMITY PRO TĚSNICÍ SEDLA Z:**
EPDM -20°C / +110°C pro kapaliny
EPDM-HT -20°C / +130°C pro kapaliny
NBR -20°C / +90°C pro kapaliny
NBR -20°C / +60°C pro plyn
VITON -10°C / +150°C pro kapaliny
VITON -10°C / +60°C pro plyn.
 - **STAVEBNÍ DÉLKY VE SHODĚ S:**
UNI EN 558 - ISO5752 - MSS SP67 - API609 - DIN3202/3-K1.
 - **HORNÍ PŘÍRUBA:** vrtání dle ISO5211.
 - **OVLÁDÁNÍ:** Páka DN40 - DN200,
Zařízení s ovládacím kolem DN250 - DN600.
 - **UZAMYKATELNÁ PÁKA:** DN40 - DN200.
 - Testováno pro vakuum 900mbar.
 - Polyuretanový nátěr.
- **NB:** vhodnost materiálů pro dané médium prosím prověřte v tabulce korozní odolnosti na konci katalogu.

SPECIÁLNÍ PŘÍKONSTRUKCE:

- Zařízení s ovládacím kolem také pro malé dimenze
- Těsnění VITON.

NA VYŽÁDÁNÍ:

- Sada pro přestavbu manuálního ovládání na automatické ovládání armatury.
- Další speciální požadavky prosím konzultujte s naším technickým/obchodním oddělením.

LIST OF VALVE COMPONENTS AND MATERIALS / SEZNAM ČÁSTÍ KLAPKY A POUŽITÝCH MATERIÁLŮ

REF.	PART. / ČÁST	Q.TY MENGE	MATERIALS / MATERIÁL				
			B302	B306	B307	B30A	B308
			B322	B326	B327	B32A	B328
1	BODY / TĚLO	1	GG40/ASTM A536				
2	PLUG / ZÁTKA	1	C.S. NICK	C.S. NICK	C.S. NICK	C.S. NICK	C.S. NICK
3	DISC / DISK	1	CF8	CF8M	CF8M	GG640N	CF8M
4	SHAFT / HORNÍ HRÍDEL	1	Type 410	SS 316	SS 316	Type 410	SS 316
4A	LOWER SHAFT / DOLNÍ HRÍDEL	1	Type 410	SS 316	SS 316	Type 410	SS 316
5	SEAT / SEDLO	1	NBR	EPDM	NBR	EPDM	VITON
10	UPPER SEAL / HORNÍ TĚSNĚNÍ	2	NBR	EPDM	NBR	EPDM	VITON
11	BUSHING / VLOŽKA	1	Delrin	Delrin	Delrin	Delrin	Delrin
12	RING / KROUŽEK	1	STEEL/OCEL	STEEL/OCEL	STEEL/OCEL	STEEL/OCEL	STEEL/OCEL
19	SCREW / ŠROUB	2	C.S. NICK	C.S. NICK	C.S. NICK	C.S. NICK	C.S. NICK
51	WASHER / TĚSNĚNÍ	1	C.S. NICK	C.S. NICK	C.S. NICK	C.S. NICK	C.S. NICK
18	LEVER HANDLE / PÁKA	1	CARBON STEEL / UHLÍKATÁ OCEL				
18	REDUCTION GEAR / ZAŘÍZENÍ S OVLÁDACÍM KOLEM	1	CAST IRON GG25 / LITINA GG25				

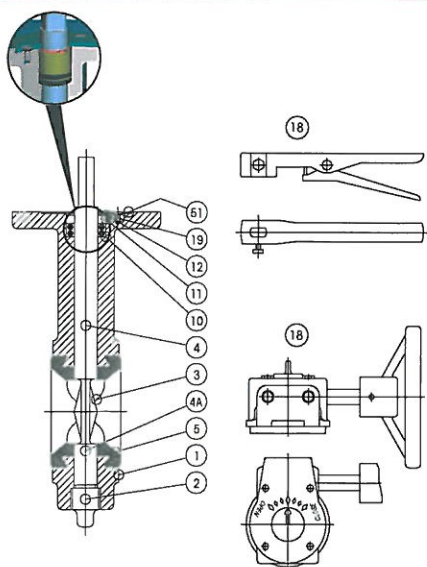

SECTION / ŘEZ

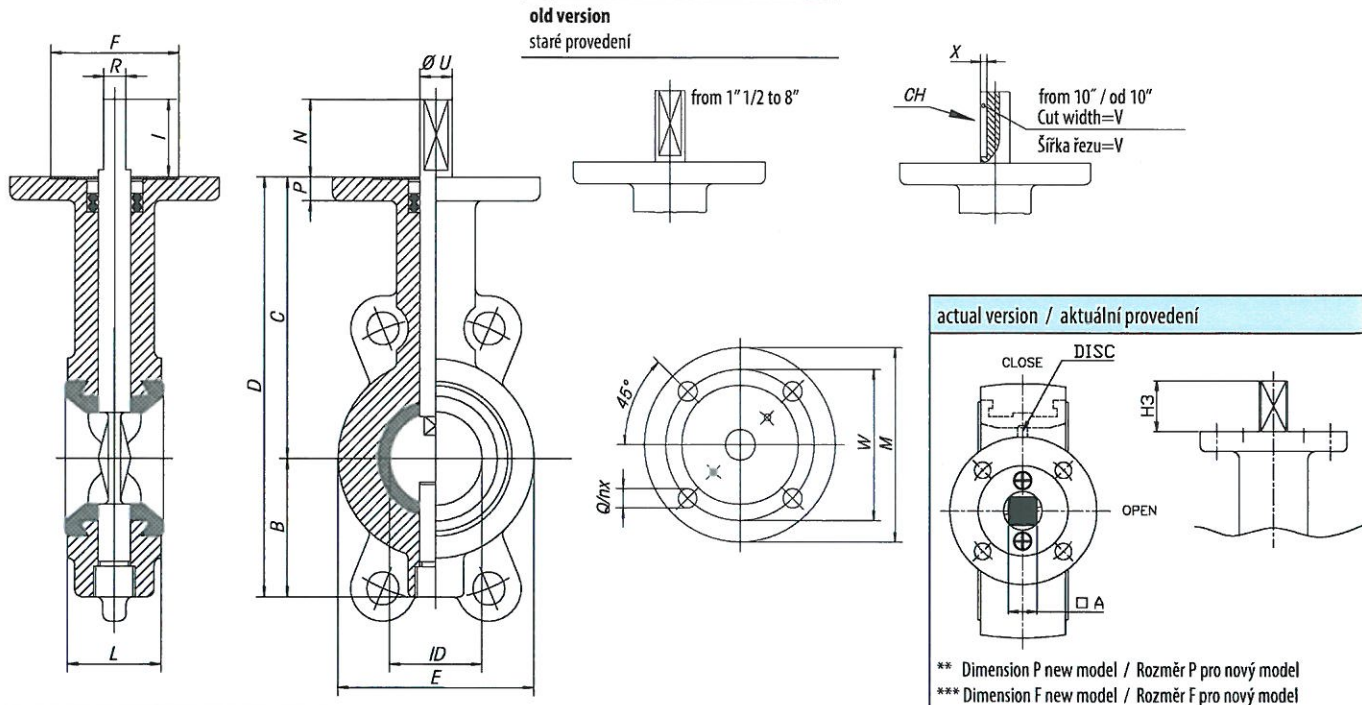

SIZE ROZMĚR	BODY / TĚLO								SHAFT / HRÍDEL										ISO5211 CONNECTION / PŘIPOJENÍ DLE ISO 5211							*
	ID	L	B	C	D	E	P	P**	N	I	R	ØU	H3	□A	X	V	CH	ATT. ISO	M	W	n	Q	F	F***	KG	
1"1/2	40	40	40	59	120	179	85	10	12	33	30	9,5	14	33	11			F07	90	70	4	9	55	55	2,7	
2"	50	50	43	64	130	194	92	11	12	33	30	9,5	14	33	11			F07	90	70	4	9	55	55	2,9	
2"1/2	65	63	46	72	137	209	107	11	12	33	30	9,5	14	33	11			F07	90	70	4	9	55	55	4,1	
3"	80	77	46	85	156	241	122	11	12	33	30	11,8	16	33	11			F07	90	70	4	9	55	55	4,4	
4"	100	100	52	95	170	265	150	11	12	33	30	11,8	16	33	11			F07	90	70	4	9	55	55	4,7	
5"	125	125	56	110	185	295	179	12	12	33	30	14,5	19	33	14			F07	90	70	4	9	55	55	6,3	
6"	150	147	56	123	203	326	206	12	12	33	30	14,5	19	33	14			F07	90	70	4	9	55	55	7,9	
8"	200	198	60	168	238	406	257	13	12	33	30	14,5	19	33	14			F07	90	70	4	9	55	58	12,3	
10"	250	244	68	203	270	473	316	15	16	65	60		22	65	17	4	8	8x7	F10	125	102	4	12	72	72	19,5
12"	300	298	78	242	310	552	370	15	16	65	60		28	65	22	4	8	8x7	F10	125	102	4	12	72	72	30,5
14"	350	352	78	290	330	620	410	15		65	60		28			4	8	8x7	F10	125	102	4	12	72		41
16"	400	399,5	102	330	375	705	468	20		75	70		38			5	12	12x8	F14	175	140	4	18	80		62
20"	500	493,5	127	400	440	840	578	20		100	95		45			5,5	14	14x9	F16	210	165	4	22	90		111
24"	600	583	154	460	510	970	680	22		100	95		55			5,5	14	14x9	F16	210	165	4	22	105		210

* Weights refer to valve with bare shaft. / * Hmotnosti odpovídají armatuře s prázdnou hřídelí.

SIZE / ROZMĚR	A	B	L	KG	
1"1/2	40	9.5	29	265	0,6
2"	50	9.5	29	265	0,6
2"1/2	65	9.5	29	265	0,6
3"	80	12	29	265	0,6
4"	100	12	29	265	0,6
5"	125	15	29	265	0,6
6"	150	15	29	265	0,6
8"	200	15	29	315	0,7

SIZE DN / ROZMĚR DN				COD.
40	50	65		RDAY608
80	100			RDAY611
125	150	200		RDAY613
250				RDAY616
300				RDAY617
350				RDAY618
400				RDAY619
500				RDAY621
600				RDAY622

NUTS AND STUD DIMENSIONS / ROZMĚRY MATEK A SPOJOVACÍCH ŠROUBŮ

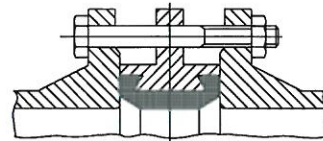
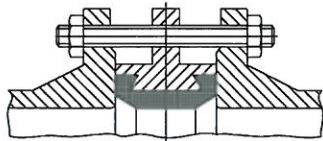

SIZE / ROZMĚR		PN10		PN16		ANSI150	
		Ø / L	N°	Ø / L	N°	Ø / L	N°
1"1/2	40	M16X110	4	M16X110	4	1/2" X 4"5/16	4
2"	50	M16X130	4	M16X130	4	5/8" X 5"1/8	4
2"1/2	65	M16X130	4	M16X130	4	5/8" X 5"1/8	4
3"	80	M16X140	8	M16X140	8	5/8" X 5"1/2	4
4"	100	M16X150	8	M16X150	8	5/8" X 5"1/2	8
5"	125	M16X150	8	M16X150	8	3/4" X 6"3/8	8
6"	150	M20X160	8	M20X160	8	3/4" X 6"3/8	8
8"	200	M20X170	8	M20X170	12	3/4" X 6"1/4	8
10"	250	M20X180	12	M24X190	12	7/8" X 7"1/2	12
12"	300	M20X190	12	M24X200	12	7/8" X 8"3/8	12
14"	350	M20X190	16	M24X220	16	1" X 8"3/4	12
16"	400	M24X230	16	M27X240	16	1" X 10"	16
20"	500	M24X250	20	M30X280	20	1"1/8 X 12"	20
24"	600	M24X300	20	M33X300	20	1"1/4 X 13"13/16	20

SIZE / ROZMĚR		PN10		PN16		ANSI150	
		Ø / L	N°	Ø / L	N°	Ø / L	N°
1"1/2	40	M16X90	4	M16X90	4	1/2" X 4"1/8	4
2"	50	M16X100	4	M16X100	4	5/8" X 4"1/4	4
2"1/2	65	M16X100	4	M16X100	4	5/8" X 4"3/4	4
3"	80	M16X100	8	M16X100	8	5/8" X 5"	4
4"	100	M16X110	8	M16X110	8	5/8" X 5"1/4	8
5"	125	M16X120	8	M16X120	8	3/4" X 5"1/2	8
6"	150	M20X120	8	M20X120	8	3/4" X 5"1/2	8
8"	200	M20X130	8	M20X130	12	3/4" X 6"	8
10"	250	M20X140	12	M24X150	12	7/8" X 6"1/2	12
12"	300	M20X160	12	M24X160	12	7/8" X 7"1/4	12
14"	350	M20X160	16	M24X170	16	1" X 8"	12
16"	400	M24X190	16	M27X200	16	1" X 8"3/4	16
20"	500	M24X200	20	M30X230	20	1"1/8 X 10"1/2	20
24"	600	M24X260	20	M33X270	20	1"1/4 X 12"	20

BREAKAWAY TORQUES in Nm / OVLÁDACÍ KROUTICÍ MOMENT v Nm

DN - bar	40	50	65	80	100	125	150	200	250	300	350	400	500	600
	1"1/2	2"	2"1/2	3"	4"	5"	6"	8"	10"	12"	14"	16"	20"	24"
0	11	14	18	27	40	59	88	157	248	343	485	662	1142	2385
6	11	20	25	32	41	62	92	173	275	382	549	766	1327	2787
10	12	23	27	34	54	71	106	186	321	551	680	882	1634	3250
16	14	25	29	37	56	86	123	262	392	576				

The values in Nm may vary as a function of the seals material, temperature and type of medium. For a firm operation of the various types of actuators, in the different working conditions it is necessary to consider a safety factor of 1,5.

Hodnoty v Nm se mohou lišit dle použitých těsnících materiálů, dle teploty a druhu média. Pro ovládání s různými typy pohonů v různých pracovních podmínkách je nutné zvážit bezpečnostní faktor 1,5.

Kv AND Cv VALUES AS A FUNCTION OF OPENING ANGLE / HODNOTY Kv a Cv V ZÁVISLOSTI NA ÚHLU OTEVŘENÍ

SIZE ROZMĚR		Kv AND Cv VALUES AS A FUNCTION OF OPENING ANGLE / HODNOTY Kv a Cv V ZÁVISLOSTI NA ÚHLU OTEVŘENÍ															
		20°		30°		40°		50°		60°		70°		80°		90°	
		ID	L	B	C	D	E	P	N	I	R	U	X	V	Z1	Z2	Z3
1"1/2	40	2,6	3	4,3	5	9,5	11	16	18	22	26	39	45	60	70	69	80
2"	50	6,7	8	7,8	9	16	18	24	28	48	55	62	72	95	110	116	135
2"1/2	65	8,6	10	13	15	23	27	38	44	73	85	95	110	145	168	181	210
3"	80	13	15	20	23	34	39	56	65	112	130	142	165	216	250	267	310
4"	100	23	27	35	41	61	71	99	115	198	230	259	300	401	465	466	540
5"	125	50	58	74	86	129	150	211	245	414	480	526	610	845	980	948	1100
6"	150	83	96	121	140	211	245	345	400	677	785	871	1010	1392	1615	1647	1910
8"	200	142	165	211	245	354	410	591	685	1099	1275	1478	1715	2302	2670	2746	3185
10"	250	220	255	328	380	560	650	974	1130	1810	2100	2328	2700	3664	4250	4224	4900
12"	300	319	370	466	540	819	950	1353	1570	2629	3050	3405	3950	5129	5950	6336	7350
14"	350	388	450	647	750	1120	1300	1905	2210	3517	4080	4836	5610	6964	8078	9655	11200
16"	400	552	640	776	900	1483	1720	2405	2790	4310	5000	6336	7650	9284	10770	11121	12900
20"	500	785	910	1375	1595	2457	2850	3991	4630	7414	8600	9914	11500	15121	17540	19310	22400
24"	600	1078	1250	1974	2290	3448	4000	5250	6090	10776	12500	14224	16500	20336	23590	24397	28300